I2C-LCD IC

BV4208



BV4208

I2C-LCD IC

Product specification

August 2008 V0.a

I2C-LCD IC**BV4208****Contents**

1.	Introduction	3
2.	Features	3
3.	Electrical Specification	3
4.	I2C Command set	4
5.	The LCD Command Set	4
5.1.	Command 1	4
5.2.	Command 2	5
5.3.	Command 3	5
5.4.	Command 4	5
5.5.	Command 5	5
5.6.	Command 6	5
6.	System Commands	6
6.1.	0x55	6
6.2.	Command 0x90	6
6.3.	Command 0x91	6
6.4.	Command 0x92	6
6.5.	Command 0x93	6
6.6.	Command 0x94	7
6.7.	Command 0x95	7
6.8.	Command 0x96	7
6.9.	Command 0x98	7
6.10.	Command 0x99	7
6.11.	Command 0xA0	7
7.	Hardware Reset	7
8.	Command Diagrams	7
8.1.	Sending a single command	8
8.2.	Sending a command with a parameter byte/s	8
8.3.	Receiving bytes from the salve	8

I2C-LCD IC**BV4208**

Rev	Change
Sept 2007	Preliminary
Oct 2008	Missing description of system commands

1. Introduction

The BV4208 is an I2C two wire compatible integrated circuit for interfacing to the HD44780 or similar LCD display. This is just about every display module available.

The chip works by converting commands derived from the I2C bus and translating that into signals suitable for the LCD display.

2. Features

- I2C up to 400kHz
- Simple command set for direct interface to LCD module
- Back light output
- Contrast pin allows display blanking
- 1,2 and 4 line displays
- 31 character buffer for I2C
- Operating voltage 2.0 to 5.5V
- Current <1mA @ 5V

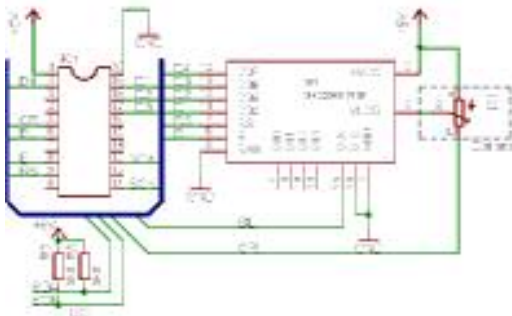
3. Electrical Specification**Figure 1 Wiring Diagram**

The chip is connected according to the wiring diagram. It should be noted that this is a 4 wire interface where only the top 4 data lines are connected to the display.

The contrast potentiometer is optional, the CR line when active provides a ground connection thus the potentiometer will set the contrast. There is an I2C command that will set this line high which will blank the display. As an option the Cr line can go directly to the VCLD pin of the LCD display.

The BL (Back Light) line is capable of sourcing or sinking up to 20mA so this can be connected to either the anode or the cathode of the LED backlight

The I2C specification calls for two pull up resistors, these must be included somewhere on the bus and so have been shown on this diagram.

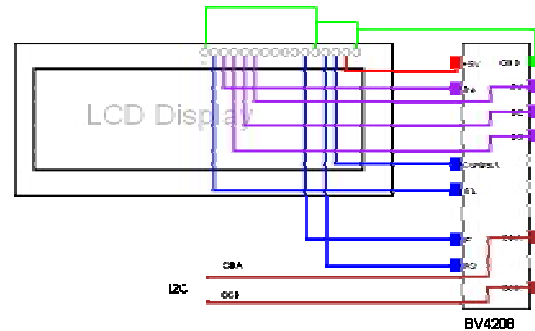
**Figure 2 Minimal Wiring**

This diagram shows the minimal wiring for making the display work.

The default for the device is set for 2 display lines with a 5 x 7 dot matrix character set. This is determined by the commands issued to the display at start up, this of course can be changed when the I2C communication is established.

**Figure 3 Sign on**

The picture in Figure 3 shows a 16 x 2 line display using the minimal wiring illustrated in Figure 2. The sign on message is 11 characters so should fit on a small display. This can be changed using a system command.

Pin	Description
1	+2.0V to 5V
2	D4: connect to D7 of the LCD display
3	Hardware reset pin: see section on hardware reset. Leave this pin unconnected
4	n/c
5	Contrast: this pin is a digital o/p that can be either high or low
6	Back Light: this pin is a digital output capable of supplying or sourcing up to 20mA
7	n/c
8	E: connect to the E pin of the LCD display
9	RS: Connect to the RS pin of the LCD display

I2C-LCD IC**BV4208**

10	n/c
11	SCK: this is the I2C clock, a pull up resistor is required on this pin 5k6 will do.
12	n/c
13	SDA: this is the I2c data, a pull up resistor is required on this pin 5k6 will do.
14	n/c
15	n/c
16	n/c
17	D3: connect this to the D6 of the LCD display
18	D2: connect this to the D5 of the LCD display
19	D1: connect this to the D4 of the LCD display
20	Ground

Table 1 IC Pin Description**4. I2C Command set**

The format used by this device consists of a command, this is a number, followed by other bytes depending on that command.

There are two type of command, those referring to the LCD and those referring to the system. The system commands enable changing of the device address etc.

Device default address is 0x42

Command	LCD Command Set
1	Send LCD Command
2	Send LCD Data
3	Back Light
4	Print Message
5	Display on
6	Message Read
Command	System Command Set
0x90	Read EEPROM
0x91	Write EEPROM
0x92	Confirm Command Complete
0x93	End of EEPROM
0x95	Reset
0x96	Factory Reset
0x98	Change Device Address Temporary
0x99	Change Device Address Permanent

Table 2 LCD & System Command Set

Table 2 is a command summary of all of the LCD and system commands.

5. The LCD Command Set

The LCD command set is a direct control of the standard internal controller chip, typically a HD44780, SPLC780D that allows simple control over the LCD display. For projects requiring simple displays this is ideal.

There are just two basic inputs to the LCD display and that is one for controlling how the display works and the other for writing characters to the display. This is taken care of by commands 1 and 2 as described later.

A useful source of information on how to control the LCD display can be found at <http://www.doc.ic.ac.uk/~ih/doc/lcd/>. This is one of many on the net.

The method of writing to the display using the I2C protocol follows a consistent format, typically:

<S-Addr><Command><data..><Stop>

Where S-Addr is the start condition followed by the device address (0x42). Command is one of the commands given in the table. Data is one or more bytes and Stop is the stop condition.

Reading data requires a restart and this will be in the format:

<S-Addr><Command><R-Addr><data..><Stop>

The restart address will be one greater then the start address, thus if the start address is 0x42, the restart address will be 0x43. Again the data can be one or more bytes read from the device.

Each command will have it's own format and is described in the following text. A start condition and address is always followed by a command. The device has an internal 32 byte I2C buffer, the effect of this is two fold:

1. Only 32 bytes can be sent to the I2C bus at any one time, this includes the command itself and any restart address that may be required.
2. The device will only respond after the stop command is received.

Using a buffer enables the I2C bus to work at full speed even though the device it may be connected to may be slower.

5.1. Command 1

Name: **Send LCD Command**

Format: <S-addr><1><byte><Stop>

This command will send data directly to the LCD as a command, i.e. with the RS line low. Using this enables the display behaviour to be altered to suit the application.

Examples for <byte>:

1 = Home and clear display

I2C-LCD IC**BV4208**

4 = This will move the cursor from right to left when a character is displayed.

6 = Default move cursor to right

0x0c = Turns cursor off

0x0e = Turns cursor on

0x0F = Cursor blinks whole character

All of the above are determined by the display controller, command 1 simply sends a byte of information to the display with the RS line low.

5.2. Command 2

Name: **Send LCD Data**

Format: **<S-addr><2><byte...><Stop>**

This will send data to be displayed on the display. The data should be ASCII coded text and **<byte..>** can be up to 30 bytes at any one time.

There is no warning that the buffer is full so it is up to the application to make sure less than 32 bytes are sent.

Examples for **<byte..>**

0x46 0x72 0x65 0x64

Writes **Fred** to the display.

5.3. Command 3

Name: **Back light**

Format: **<S-addr><3><1 or 0><Stop>**

This command controls the back light pin as a digital output. It is the inverse of the number sent so a 1 would place a logic 0 on the pin and a 0 would place a logic 1 on the pin.

If not used for the back light this can be used as a general purpose output pin.

5.4. Command 4

Name: **Print Message**

Format: **<S-addr><4><EEPROM Address><Stop>**

This will print a string contained in the EEPROM to the display at the address given at EEPROM Address. The string can consist of commands and characters and follows this format:

0x0 Terminates the string

0x01 Next byte that follows is an LCD command

Anything else will be sent to the display as LCD data. See command 6 for creating a new sign-on message.

Example:

0x01 0x01 0x46 0x72 0x65 0x64 0x00

The first byte 0x01 tells the controller to interpret the next byte as a command, the command in byte 2 0x01 will be sent to the display as a command and thus it will clear the display and home the cursor. The sting "0x46 0x72 0x65 0x64" is ASCII for Fred and this is terminated with 0x00.

5.5. Command 5

Name: **Display on**

Format: **<S-addr><5><0 or 1><Stop>**

This directly controls the contrast output and is the inverse. A one in this command will take the contrast pin low, thus enabling the display. A 0 on this command will take the contrast pin high and thus blank the display.

5.6. Command 6

Name: **Message Area**

Format: **<S-addr><6><R-Addr><data><Stop>**

The value returned from this command is the EEPROM address of the sign on message. A new message can be placed here to customise the start up message.

This address up to the end of EEPROM can be used for any purpose including other custom messages. The end of the EEPROM can be determined by system command 0x93

I2C-LCD IC**BV4208**

Rev	System Section Changes
Oct 2008	Preliminary

6. System Commands

The following section deals with system commands that are common to all I2C devices. Note that not all of these commands are available for all devices.

Command	System Command Set
0x55	Test
0x90	Read EEPROM
0x91	Write EEPROM
0x92	Confirm Command Complete
0x93	End of EEPROM
0x94	Sleep
0x95	Reset
0x96	Factory reset
0x98	Change Device Address Temporary
0x99	Change Device Address Permanent
0xA0	Firmware Version

Most but not all devices contain an EEPROM that can store data when the power is off. The first 16 bytes of the memory is reserved for system use and should not be changes by using these commands.

If the contents of the first 16 bytes are changed then, depending on the device unpredictable results may occur. A factory reset will put the contents back to normal. In some devices not all 16 bytes are used.

The rest of the EEPROM can be used by the user for any purpose.

6.1. 0x55

Name: **Test**

Format: < **S-addr**><**0x55**><**start**><**R-Addr**><**Value..**><**NACK**><**Stop**>

BV4221 Example

```
0x42>s 55 r g-3 p
```

The above command will return 1,2,3 if the device is connected and working correctly.

This command simply returns an incrementing value until NACK is sent by the master prior to stop. This can be useful for testing the interface.

It can be used for testing the presence or other wise of a device at a particular address. It is also useful during the development stage to ensure that the I2C is working for that device.

6.2. Command 0x90

Name: **Read EEPROM**

Format: <**S-addr**><**0x90**><**EE-Address**><**R-Addr**><**data...**><**Stop**>

BV4221 Example

```
0x42>s 90 r g-3 p
```

The above will fetch 3 bytes from the EEPROM addresses 0, 1 and 2

This command will allow a single or several bytes to be read from a specified EEPROM address. A maximum of 30 bytes can be read at any one time, this restriction is due to the size of the I2C buffer.

6.3. Command 0x91

Name: **Write EEPROM**

Format: <**S-addr**><**0x91**><**EE-Address**><**data...**><**Stop**>

BV4221 Example

```
0x42>s 91 10 1 2 3 p
```

The above write 1,2 and 3 to EEPROM addresses 0x10, 0x11 & 0x12

This command will write one or more, up to a maximum of 30 bytes at any one time, to be written to the EEPROM. Address 0 of the EEPROM is the device address and this cannot be written to by this command. A special command 0x99 is used for this purpose.

The first 16 bytes 0 to 15 are reserved for system use.

6.4. Command 0x92

Name: **Confirm Write to EEPROM**

Format: <**S-addr**><**0x92**><**R-Addr**><**data**><**Stop**>

BV4221 Example

```
0x42>s 92 r g-1 p
```

EEPROM write operations are not instantaneous. This command will return a value of 1 if the EEPROM is still in the progress of writing otherwise it will return 0.

This command should be issued before command 0x91 is used.

6.5. Command 0x93

Name: **End of EEPROM**

I2C-LCD IC**BV4208**

Format: <S-addr><0x93><R-Addr><data><Stop>

BV4221 Example

0x42>s 93 r g-1 p

Returns the address of the end of the EEPROM, normally 0xff

The system only uses a small portion of the first part of the EEPROM, the rest of the EEPROM can be used for user data or other purposes depending on the device. This command returns a single byte that will determine the last writeable address of EEPROM, normally 0xFF.

6.6. Command 0x94

Name: **Sleep**

Format: <S-addr><0x94><Stop>

BV4221 Example

0x42>s 94 p

This will put the IC into sleep mode. Any other command will wake the IC. Depending on the device this can be a considerable power saving.

6.7. Command 0x95

Name: **Reset**

Format: <S-addr><0x95><Stop>

BV4221 Example

0x42>s 95 p

Resets the device, this is equivalent to disconnecting and then connecting the power again

6.8. Command 0x96

Name: **Factory Reset**

Format: <S-addr><0x96><0x55><0xaa><Stop>

BV4221 Example

0x42>s 96 55 aa p

Resets the device to its factory default, this is the software equivalent of the Hardware reset. The address and all other relevant EEPROM information will be restored.

** Note earlier firmware does not require the 55 aa bytes **

6.9. Command 0x98

Name: **Change Device Address Temporary**

Format: <S-addr><0x98><New-Addr><Stop>

BV4221 Example

0x42>s 98 62 p

Changes the device address to 0x62, the device will revert back to 0x42 at reset.

This will change the device address with immediate effect and so the next command must use the new address. The address must be a write address (even number) Odd numbers will simply be ignored. The effect will last as long as the device is switched on. Resetting the device will restore the address to its original value. The address is stored in EEPROM location 0.

6.10. Command 0x99

Name: **Change Device Address Permanent**

Format: <S-addr><0x99><New-Addr><0x55><0xaa><Current-Addr><Stop>

BV4221 Example

0x42>s 99 62 55 aa 42 p

Permanently changes the device address to 0x62.

This command changes the address immediately (the next command will need to use the new address) and permanently (see hardware reset). The address must be a write address (even number) and follow the sequence exactly.

Permanent in this case means that the device will retain this address after power down, i.e. it is stored in EEPROM. Should anything go wrong the default address can be restored by using a hardware reset.

6.11. Command 0xA0

Name: **Firmware version**

Format: <S-addr><a0><R-Addr><byte><byte><Stop>

BV4221 Example

0x42>s a0 r g-2 p

This will return the two firmware bytes.

This simply returns two bytes that represents the firmware version.

7. Hardware Reset

A hardware reset has been provided should the device address be changed to some unknown value. For this device simply hold the Address reset pin low whilst power up takes place. The device will then be reset back to its default address.

8. Command Diagrams

To further explain the format of the commands this section has been provided.

I2C-LCD IC**BV4208**

The design of the interface has been purposely kept simple and so there are only a few standard sequences required.

Key

Master

Slave

S Start condition

P Stop Condition

A Acknowledge = 1

N Not acknowledge = 0

8.1. Sending a single command

This is designated in the list as:

<S-addr><cmd><Stop>

This sequence is used for simple functions where no data is involved. The I2C sequence, using the default address is:

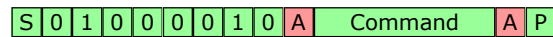
**8.2. Sending a command with a parameter byte/s**

This is designated in the list as:

<S-addr><cmd><data...><Stop>

Some commands expect a parameter after the command. In this case the bytes are sent one after the other up to the maximum of 31 bytes. The stop command tells the slave that there is a command ready to be executed.

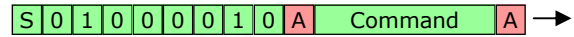
**8.3. Receiving bytes from the slave**

<S-addr><cmd-Addr><byte><Stop>

When receiving one or a number of bytes from the device a restart is required.

The command is sent with an even address (the R/W bit 0). When the slave acknowledges the command another start condition is sent with the R/W bit set to 1. This is called a restart. After this restart the slave will continue to send bytes until the master sends a not acknowledge (N or NACK).

If the master does not send a NACK at the last byte the slave will be expecting another byte to be requested and this may cause either unpredictable results or the I2C bus to lock.

